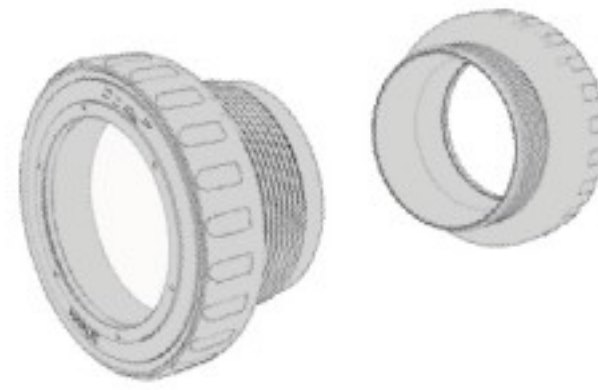
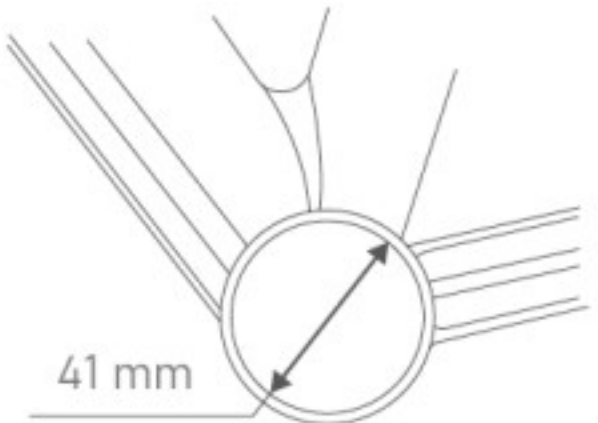
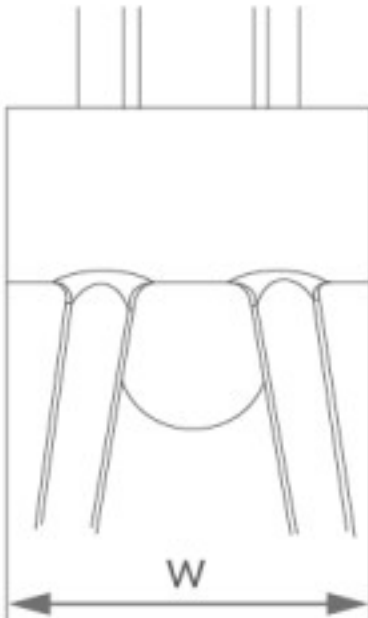

TRP BB & Crankset Compatibility Chart

BSA BB - M8000

Determine the type of your BB shell	BB shell frame width	BB model	Fully assembled width	Non-drive side spacer usage	Drive side spacer usage	Use the following crankset
 	68mm (Road)		96mm	1 x 2.5mm	2 x 2.5mm	FC-M9050 FC-M8050
	73mm (Mountain)		73mm	✗	1 x 2.5mm	FC-M9050 FC-M8050
	83mm (DH)		111mm	1 x 2.5mm	2 x 2.5mm	FC - M8070

PF92 BB - M8010

Determine the type of your BB shell	BB shell frame width	BB model	Fully assembled width	Non-drive side spacer usage	Drive side spacer usage	Use the following crankset
 	89.5mm (Mountain)		96mm	✗	1 x 2.5mm	FC-M9050 FC-M8050
	92mm (Mountain)		96mm	✗	✗	FC-M9050 FC-M8050
	104.5mm (DH)		111mm	✗	1 x 2.5mm	FC - M8070
	104.7mm (DH)		111mm	✗	✗	FC - M8070

PF30 BB - M8020

Determine the type of your BB shell	BB shell frame width	BB model	Fully assembled width	Non-drive side spacer usage	Drive side spacer usage	Use the following crankset
 	73mm (Mountain)		96mm	✗	1 x 2.5mm	FC-M9050 FC-M8050
	83mm (DH)		111mm	1 x 2.5mm	2 x 2.5mm	FC - M8070